

# **ROBOTS THAT RUN**

**COURTESY OF MARC RAIBERT,  
MIT, CAMBRIDGE, MA**

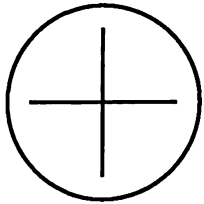

# **WALKERS**

**EXCERPTS COURTESY OF MARC RAIBERT AND  
THE MIT PRESS, MIT, CAMBRIDGE, MA;  
CHARLES KLEIN, OHIO STATE UNIVERSITY, COLUMBUS OH;  
AND ODETICS, INC., ANAHEIM, CA**

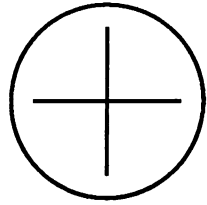

**FORGET**

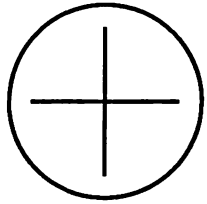

**TEACH**

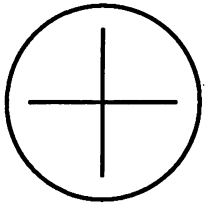

**GO**

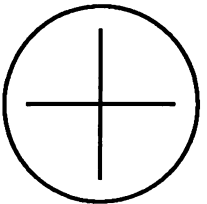

**MAGNET**

**PRESS ANY  
BUTTON FOR  
INSTRUCTIONS**

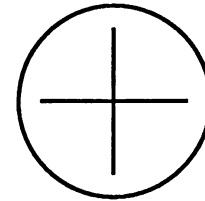

**MOVE**

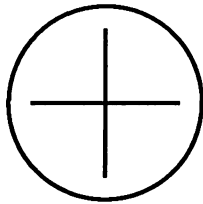

**HAROLD COHEN TALKS TO RAY KURZWEIL ABOUT**

# **AARON**

**VIDEO COURTESY OF  
THE KURZWEIL FOUNDATION, WALTHAM, MA**

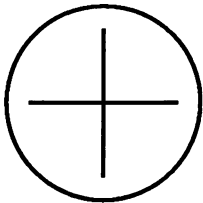

**COMPUTER UNDERSTANDING OF EXPRESSION IN**

# **MUSICAL PERFORMANCE**

**VIDEO COURTESY OF  
BARRY VERCOE, IRCAM, PARIS,  
AND MEDIA LABORATORY, MIT, CAMBRIDGE, MA**

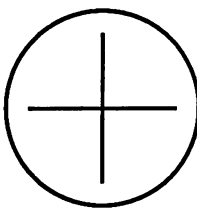

**SPEAK  
HERE**

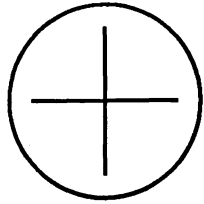

# ROAM

**PRESS TO MAKE THE ROBOT GUIDE ITSELF.  
IT WILL DETECT OBSTACLES AND DRAW A MAP.**

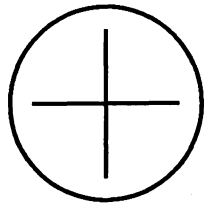

# JOYSTICK

**PRESS TO CONTROL THE ROBOT YOURSELF  
WITH THE JOYSTICK. THE ROBOT WILL TRY TO AVOID OBSTACLES.**

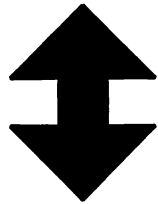

# MOVE



# SPIN

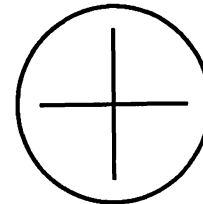

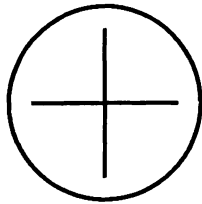

**EXCERPTS FROM**

# **BALLET ROBOTIQUE**

**PRODUCED BY BOB ROGERS AND COMPANY, INC.,  
BURBANK, FOR GENERAL MOTORS.  
DONATED BY GENERAL MOTORS RESEARCH  
LABORATORY, WARREN, MICHIGAN**

top

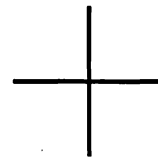
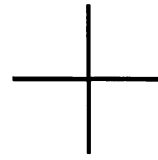
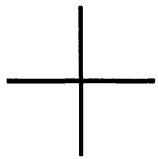
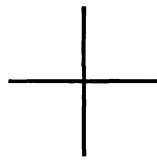
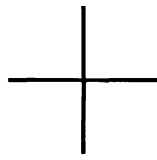
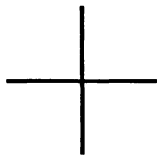
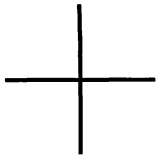

bottom

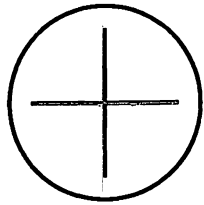

# **DEXTEROUS HANDS**

**EXCERPTS FROM "DISCOVER: THE WORLD OF SCIENCE"  
COURTESY OF THE CHEDD ANGIER PRODUCTION COMPANY,  
WATERTOWN, MA, STEVE JACOBSEN, UNIVERSITY OF UTAH,  
AND KENNETH SALISBURY, MASSACHUSETTS INSTITUTE OF TECHNOLOGY.**



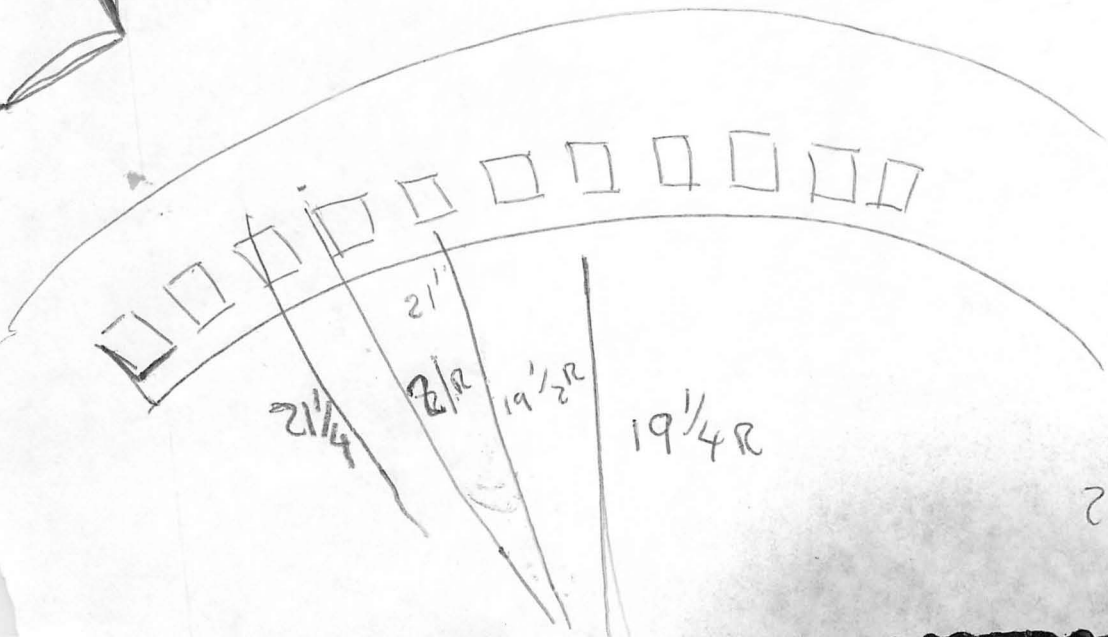

$20\frac{1}{4}$

# 3 CIRCLES

- ① RADIUS  $32\frac{5}{8}$ "
- ⑦ RADIUS  $19\frac{1}{4}$ " - ARC  $240^\circ$  6" HIGH TOP
- ③ RADIUS 12" - ARC  $120^\circ$  3" HIGH TOP

BASE

HEXAGON

$32\frac{5}{8}$

3" HIGH



TWO SHORT SIDES  
 $17\frac{1}{16}$

ADDITION TO MAKE SIDE FACING

PLATE ~~TO BE~~ FLUSH WITH FRONT  
OF PANELS

6" HIGH

3 SIDES NORMAL

LEFT SIDE  $16\frac{5}{16}$

RIGHT SIDE  $16\frac{5}{16}$

PLUS IT STICKS OUT AN EXTRA  
 $1\frac{1}{8}$ "

1  
2  
3  
4  
5  
6  
7  
8  
9  
10  
11  
12  
13  
14  
15  
16  
17  
18  
19  
20  
21  
22  
23  
24  
25  
26  
27  
28  
29  
30  
31  
32  
33  
34  
35  
36  
37  
38  
39  
40  
41  
42  
43  
44  
45  
46  
47  
48  
49  
50  
51  
52  
53  
54  
55  
56  
57  
58  
59  
60  
61  
62  
63  
64  
65  
66  
67  
68  
69  
70  
71  
72  
73  
74  
75  
76  
77  
78  
79  
80  
81  
82  
83  
84  
85  
86  
87  
88  
89  
90  
91  
92  
93  
94  
95  
96  
97  
98  
99  
100

MITSUBISHI  
ARM

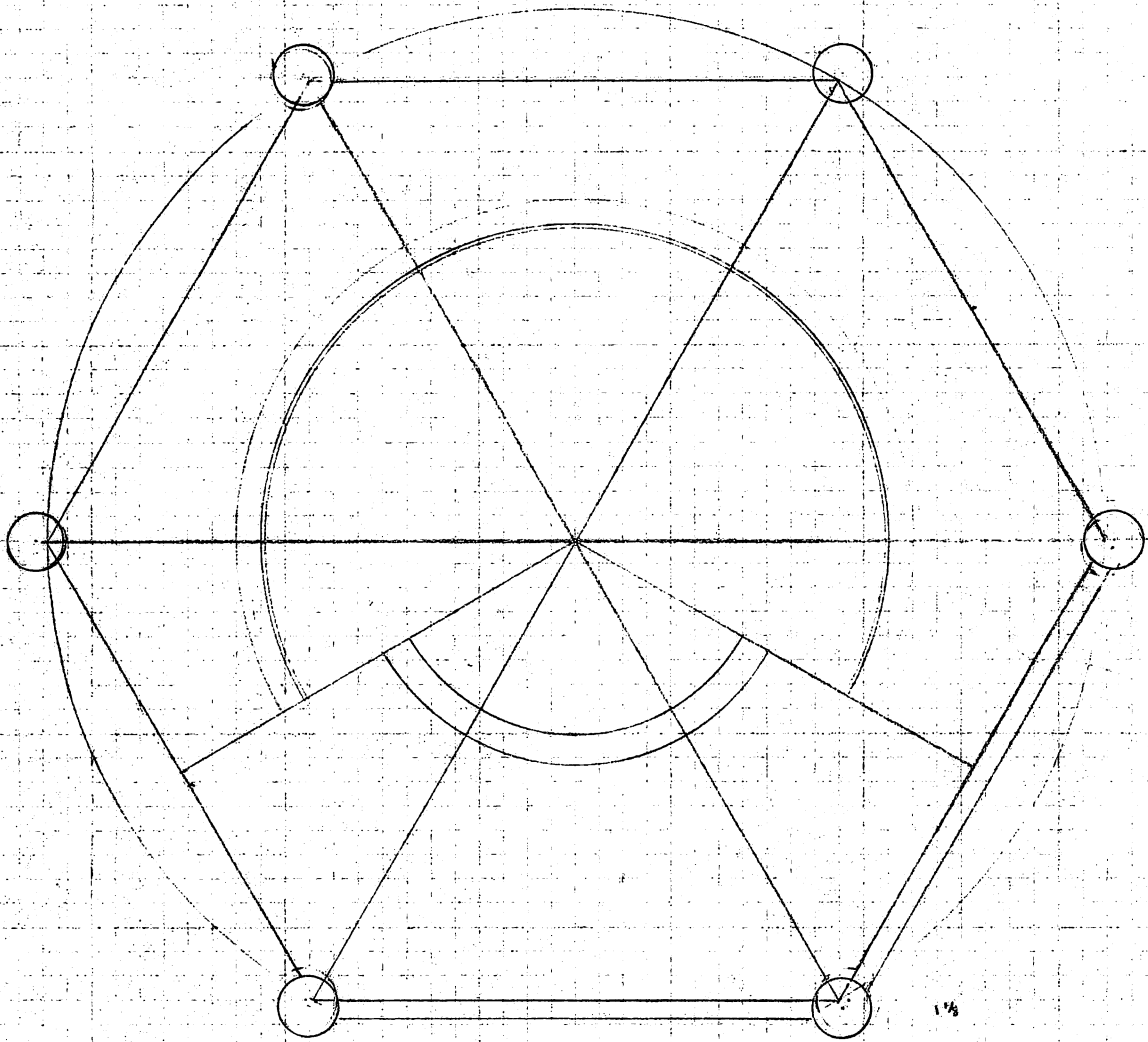

$$\begin{array}{r} 30 \frac{5}{16} \\ \cancel{10} \frac{5}{16} \\ \hline 32 \frac{5}{16} \end{array}$$

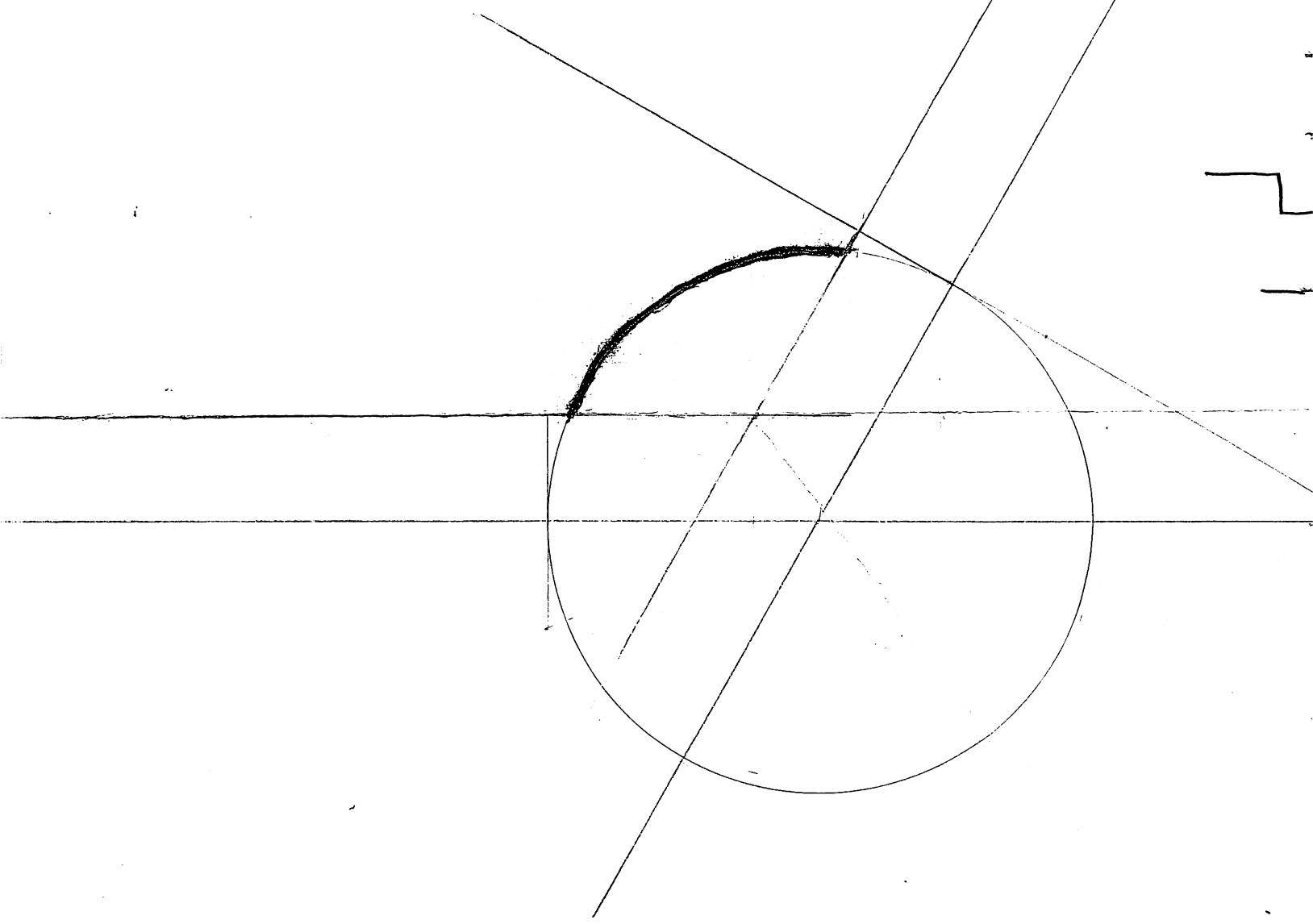

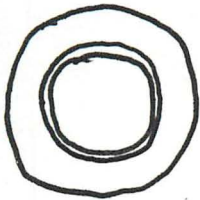

HAROLD COHEN TALKS TO RAY KURZWEIL ABOUT

**AARON**

VIDEO COURTESY OF: THE KURZWEIL FOUNDATION, WALTHAM, MA

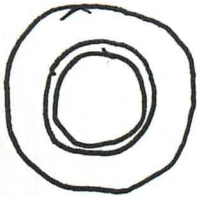

COMPUTER UNDERSTANDING OF EXPRESSION IN

**MUSICAL**

**PERFORMANCE**

VIDEO COURTESY OF: BARRY VERCOE, IRCAM, PARIS, AND  
MEDIA LABORATORY, MIT, CAMBRIDGE, MA

6.9.87

OLIVER,

I REALIZE THAT SOME  
OF THE TEXT HAS  
CHANGED, BUT THIS  
IS THE APPROACH WE  
ARE TAKING -  
DAVID

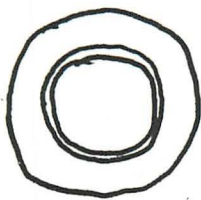

HAROLD COHEN TALKS TO RAY KURZWEIL ABOUT

**AARON**

VIDEO COURTESY OF: THE KURZWEIL FOUNDATION, WALTHAM, MA

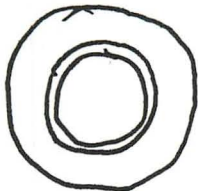

COMPUTER UNDERSTANDING OF EXPRESSION IN

**MUSICAL**

**PERFORMANCE**

VIDEO COURTESY OF: BARRY VERCOE, IRCAM, PARIS, AND  
MEDIA LABORATORY, MIT, CAMBRIDGE, MA

6.9.87

TOM -

THE FRONT PULS ARE  
ALL 8" x 8". THE  
PLACEMENT & DIA OF  
HOLE WILL BE  
DETERMINED TOMORROW

DAVID

3/10

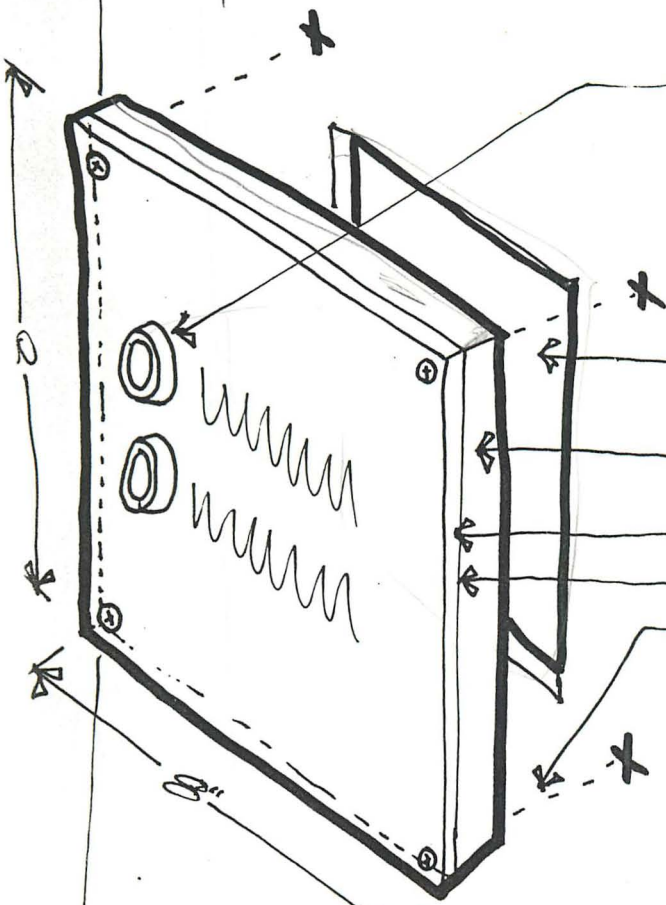
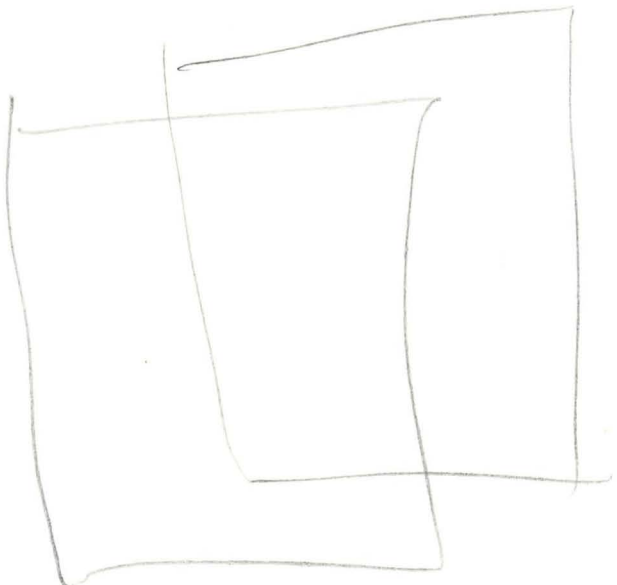

BUTTONS TO MOUNT ON MASCHITE - HOLES IN PLEXI TO CLEAR OD OF BUTTON COLLARS

CUT CABLE ACCESS IN PANEL

MASCHITE PAINT EDGES BLACK

CLEAR PLEXI

PHOTO STAT

SCREW DIRECTLY TO WALL PANEL AT 4 CORNERS PAINT SCREW HEADS BLACK

### BUTTON PANELS FOR ART: MUSIC AND GRIPPER VIDEOS

NOTE: GRIPPER PANEL HAS ONLY TOP BUTTON.

- 2 REQUIRED
- 1 W/ ONE BUTTON
- 1 W/ TWO BUTTONS



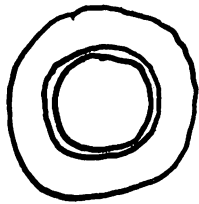

**WALKING ROBOTS**

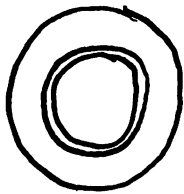

**RUNNING ROBOTS**

VIDEO COURTESY OF: MARC RAIBERT,  
MASSACHUSETTS INSTITUTE OF TECHNOLOGY, AND  
MIT PRESS, CAMBRIDGE MA

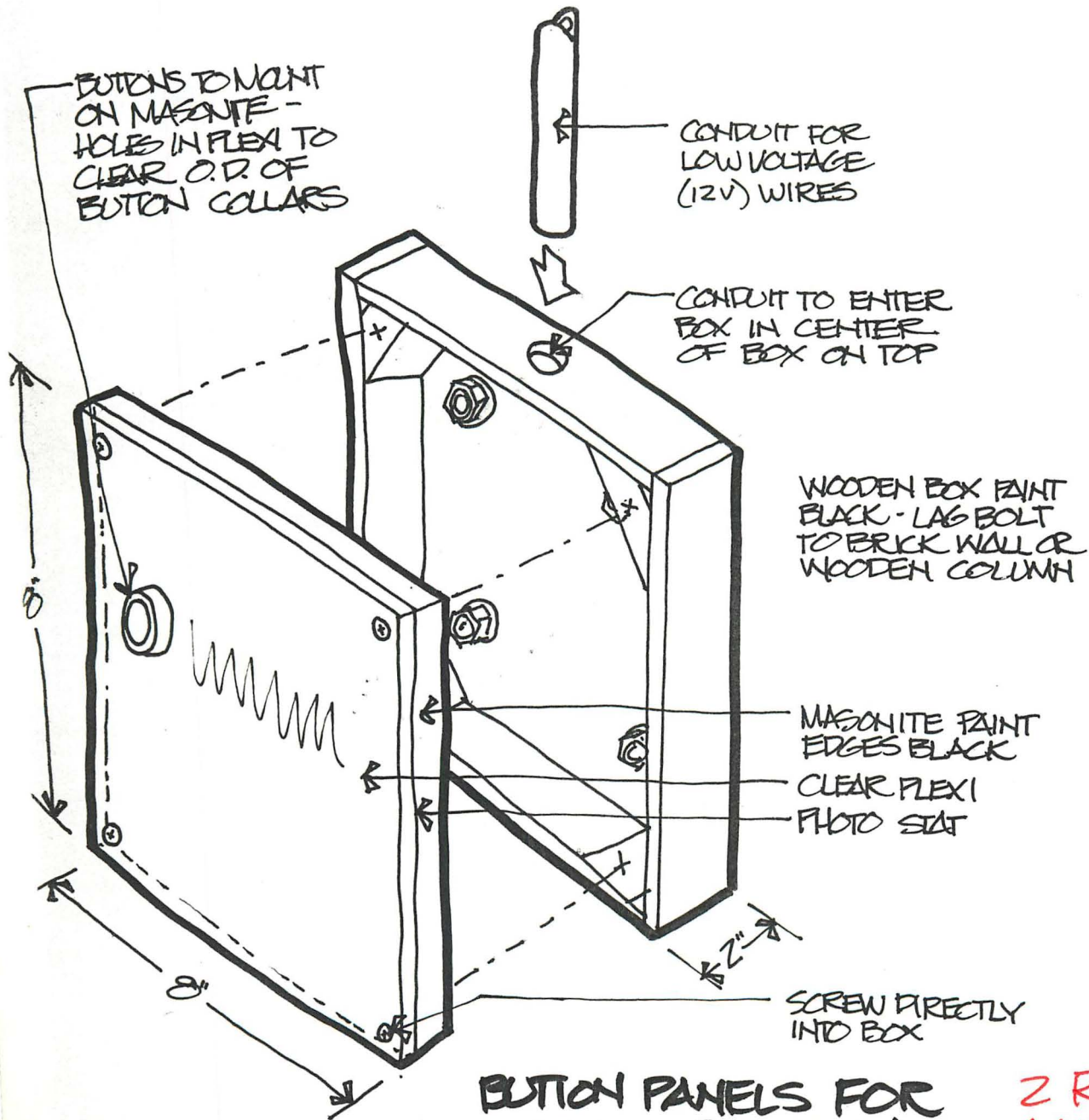

**BUTTON PANELS FOR HOPPING ROBOTS & INDUSTRIAL ROBOTS**

NOTE: HOPPING ROBOTS HAS TWO BUTTONS

2 REQUIRED  
 1 w/ ONE BUTTON  
 1 w/ TWO BUTTONS

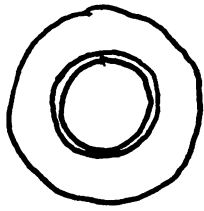

**ROAM**

PRESS TO MAKE THE ROBOT GUIDE ITSELF.  
IT WILL DETECT OBSTACLES AND DRAW A MAP.

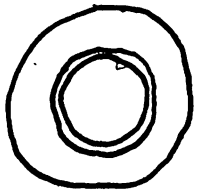

**JOYSTICK**

PRESS TO CONTROL THE ROBOT YOURSELF.

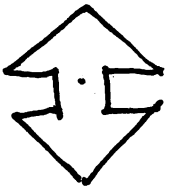

**MOVE**

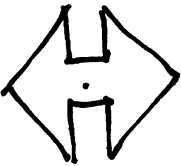

**TURN**

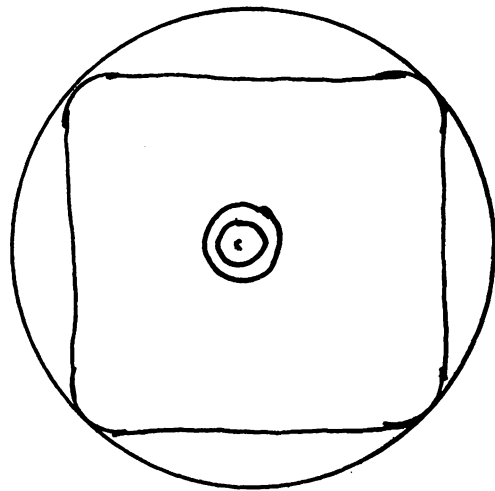

TICK OPENING IN  
1 1/2" STANDOFF  
X TO BE = DIA.

BUTTONS TO MOUNT  
ON MASONITE -  
HOLES IN FLEXI TO  
CLEAR O.D. OF  
BUTTON COLLARS

SCREW DIRECTLY  
TO DESK TOP AT  
4 CORNERS -  
PAINT SCREW  
HEADS BLACK

CLEAR FLEXI

MASONITE BLACK EDGES

PHOTO STAT

WOODEN  
STANDOFF  
BLOCK - PAINT  
BLACK - GLUE  
TO MASONITE  
W/ D SCREW

CUT 8x8"  
SQUARE IN  
EUROTUX  
CENTERED OVER  
ACCESS OPENING  
IN DESK TOP

W/ STICK - STRAP  
O STANDOFF  
BLOCK W/ PIPE  
LARGERS AS  
REQUIRED

**BUTTON PANEL FOR  
MOBILE BASE** ONE REQUIRED

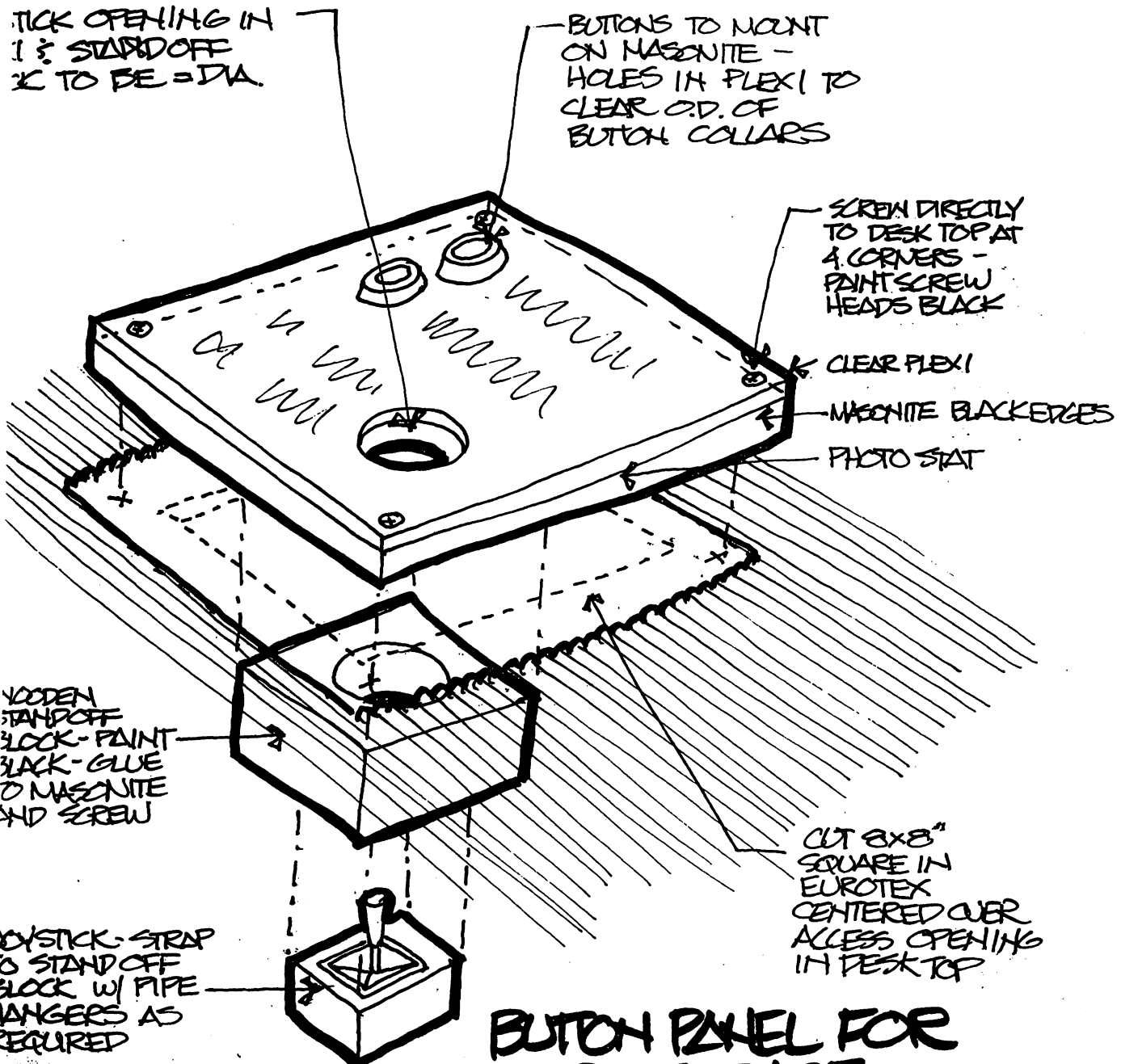

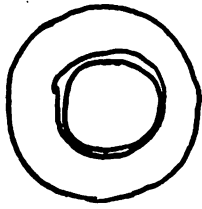

**FORGET**

PRESS ANY BUTTON  
FOR INSTRUCTIONS

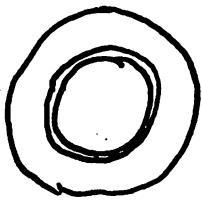

**TEACH**

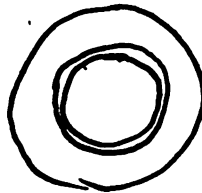
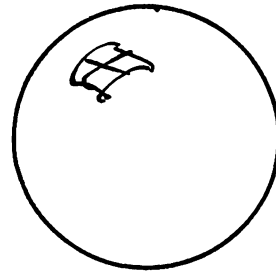

**GO**

**MOVE**

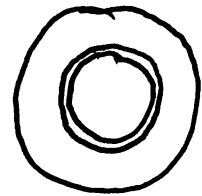

**MAGNET**

ADD BLOCKING TO  
BACK OF MASONITE  
AS REQ'D TO  
FIRMLY MOUNT  
JOYSTICK FROM  
BEHIND

SCREW DIRECTLY TO  
ANGLED BOX AT 4  
CORNERS - PAINT  
SCREW HEADS BLACK

BUTTONS TO MOUNT  
ON MASONITE -  
HOLES IN PLEXI TO  
CLEAR O.D. OF  
BUTTON COLLARS

MASONITE - PAINT  
EDGES BLACK  
CLEAR PLEXI  
PHOTO STAT

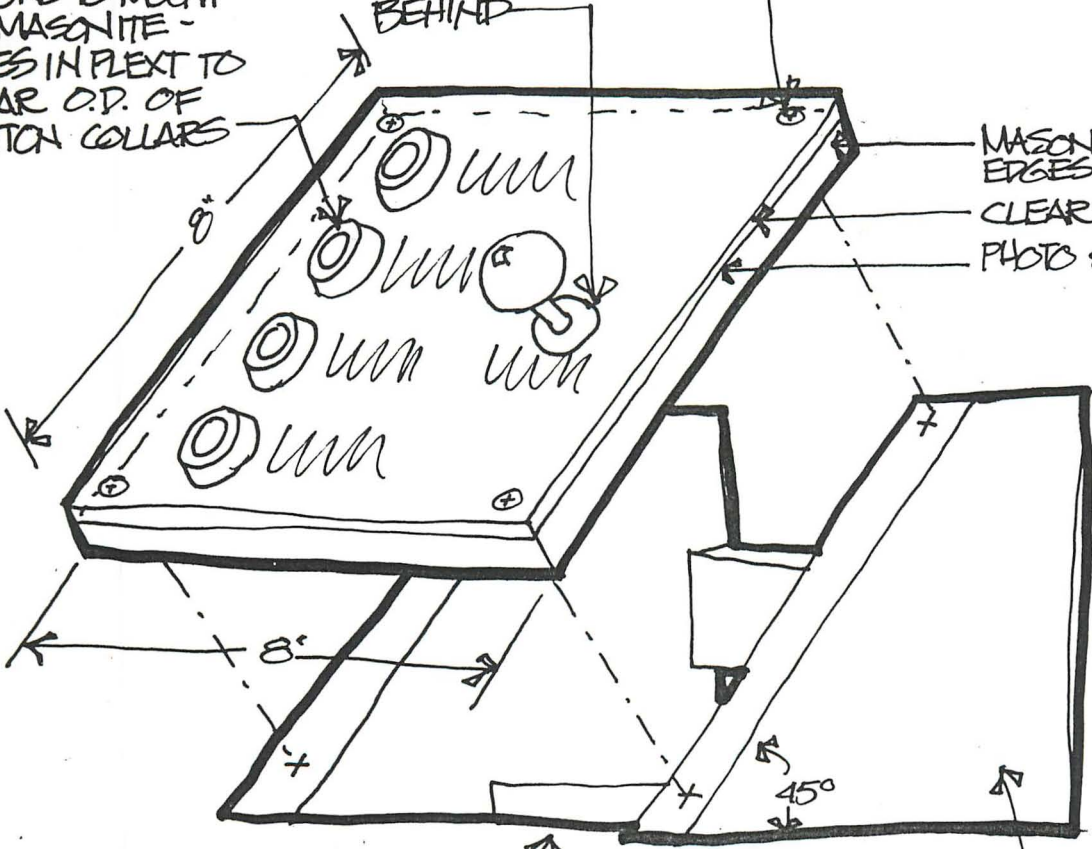

BOLT TO KEYBOARD TRAY  
FROM BELOW TO SECURE

3/4" PLYWOOD BOX  
PAINT EXPOSED  
SURFACES BLACK

# BUTTON PANELS FOR FISHER TECHNIQUE ARMS

2 REQUIRED

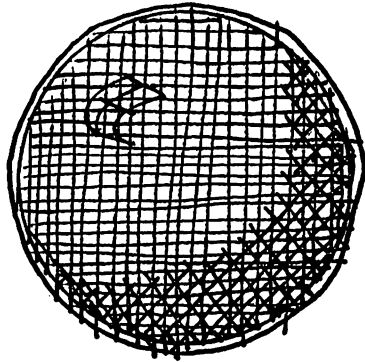

**SPEAK  
HERE**

ADD BLOCKING TO  
BACK OF MASCHITE  
AS REQ'D TO  
FIRMLY MOUNT  
MICROPHONE

SCREW DIRECTLY TO  
ANGLED BOX AT 4  
CORNERS - PAINT  
SCREW HEADS BLACK

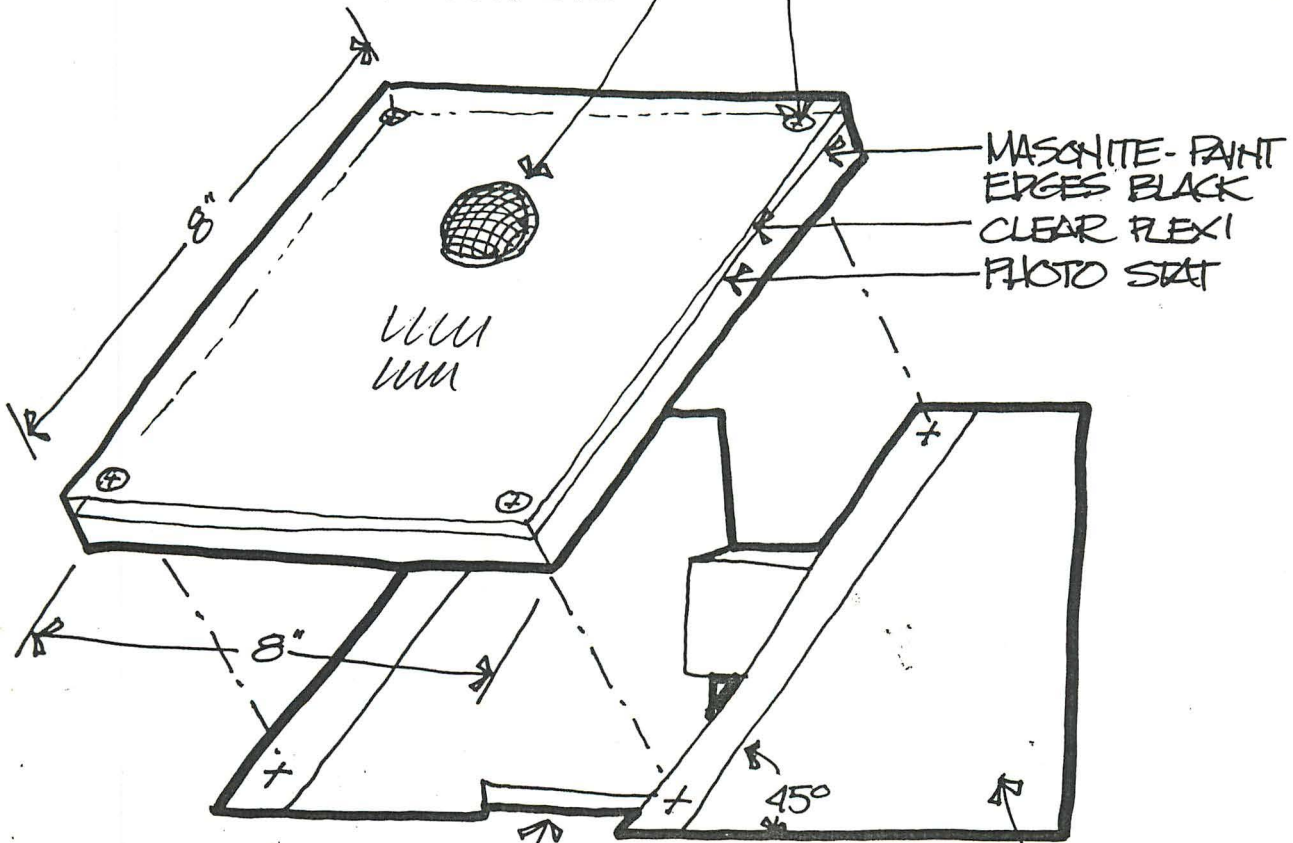

MASCHITE - PAINT  
EDGES BLACK  
CLEAR FLEXI  
PHOTO STAT

BOLT TO KEYBOARD TRAY  
FROM BELOW TO SECURE

3/4" PLYWOOD BOX  
PAINT EXPOSED  
SURFACES BLACK

3 REQUIRED

MICROPHONE PANELS



**THIS SHIPPING ORDER**

must be legibly typed in, in ink, in indelible pencil, or in Carbon, and retained by the Agent.

DESIGNATE WITH AN (X)

RECEIVE, subject to the classifications and tariffs in effect on the date of issue of this Shipping Order.

BY TRUCK  FREIGHT

the property described below, in apparent good order, except as noted (contents and condition of contents of packages unknown), marked, consigned and destined as indicated below, which said carrier (the word carrier being understood throughout this contract as meaning any person or corporation in possession of the property under the contract) agrees to carry to its usual place of delivery at said destination, if on its route, otherwise to deliver to another carrier on the route to said destination. It is mutually agreed, as to each carrier of all or any of said property over all or any portion of said route to destination, and as to each party at any time interested in all or any of said property, that every service to be performed hereunder shall be subject to all the terms and conditions of the Uniform Domestic Straight Bill of Lading set forth (1) in Uniform Freight Classification in effect on the date hereof, if this is a rail or a rail-water shipment, or (2) in the applicable motor carrier classification or tariff if this is a motor carrier shipment.

Shipper hereby certifies that he is familiar with all the terms and conditions of the said bill of lading, including those on the back thereof, set forth in the classification or tariff which governs the transportation of this shipment, and the said terms and conditions are hereby agreed to by the shipper and accepted for himself and his assigns.

From **BOSHO, INC.**  
At **42 MANNING ROAD, BILLERICA, MASS.**  
(Mail or street address of consignee—For purposes of notification only.)

DATE	SHIPPER'S NO.
3/17 19 87	
CARRIER	CARRIER'S NO.
↓	
BY	
Customer Pick Up	
ROUTE	DELIVERING CARRIER
CAR OR VEHICLE INITIALS & NO.	

CONSIGNEE AND DESTINATION  
**The Computer Museum**  
**300 Congress St.**  
**Boston, MA 02110**  
**Attn: Tom Merrill**

NO. PACKAGES	HAZARDOUS MATERIALS	DESCRIPTION OF ARTICLES, SPECIAL MARKS AND EXCEPTIONS	*WEIGHT (SUBJECT TO CORR.)	CLASS OR RATE	✓
1		New Delta Model #37223 6" jointer, 3.5 HP, 1 phase.			
1		New Delta 14" wood bandsaw, 7.5 HP, 1 phase.			
1		New Delta Unifence Model 34-897			
IX		<del>Return to Billerica from Tool Shed</del>			

Subject to Section 7 of conditions of applicable bill of lading, if this shipment is to be delivered to the consignee without recourse on the consignor, the consignor shall sign the following statement.  
The carrier shall not make delivery of this shipment without payment of freight and all other lawful charges.  
Per \_\_\_\_\_  
(Signature of Consignor)  
If charges are to be prepaid, write or stamp here, "To be Prepaid."  
Received \$ \_\_\_\_\_  
to apply in prepayment of the charges on the property described hereon.  
Agent or Cashier.  
Per \_\_\_\_\_  
(The signature here acknowledges only the amounts prepaid.)  
Charges Advanced: \$ \_\_\_\_\_

SHIPPER'S CERTIFICATION: This is to certify that the above-named materials are properly classified, described, packaged, marked and labeled, and are in proper condition for transportation according to the applicable regulations of the Department of Transportation.  
SIGNATURE \_\_\_\_\_ TITLE \_\_\_\_\_

\* If the shipment moves between two ports by a carrier by water, the law requires that the bill of lading shall state whether it is "carrier's or shipper's weight."  
† Shipper's imprints in lieu of stamp; not a part of Bill of Lading approved by the Interstate Commerce Commission.  
Note — Where the rate is dependent on value, shippers are required to state specifically in writing the agreed or declared value of the property.  
The agreed or declared value of the property is hereby specifically stated by the shipper to be not exceeding \_\_\_\_\_

**C.O.D. SHIPMENT**  
C.O.D. Amt \_\_\_\_\_  
Collection Fee \_\_\_\_\_  
Total Charges \_\_\_\_\_

THIS SHIPMENT IS CORRECTLY DESCRIBED.  
CORRECT WEIGHT IS \_\_\_\_\_ LBS.  
† The fibre boxes used for this shipment conform to the specifications set forth in the box makers certificate thereon, and all other requirements of the Consolidated Freight Classification.  
Per RRB Shipper

**BOSHO, INC.**  
**42 MANNING ROAD, BILLERICA, MASS. 01821 - TEL (617) 667-1911**  
Permanent post office address of shipper

Shipper, Per \_\_\_\_\_  
Agent must detach and retain this Shipping Order and must sign the Original Bill of Lading.  
*Tom Merrill*

2

# Boshco, Inc.

24358

(617) 667-1911

OUR MASS. TOLL FREE NO. IS 1-800-442-4438

NEW ——— WOODWORKING MACHINERY ——— USED

42 MANNING ROAD — P. O. BOX 817  
BILLERICA, MASS. 01821

**SOLD TO**

The Computer Museum  
300 Congress Street  
Boston, MA 02110

DATE March 17, 1987  
INV. NO. 24358  
YOUR ORDER NO. Verbal  
TERMS Net Cash  
SHIPPED VIA Your Truck 3/17/87

- 1 - New Delta #37-223 6" jointer with 3/4 HP, 1 phase motor and all standard equipment.
- 1 - New Delta 14" wood band saw with 3/4 HP, 1 phase motor.
- 1 - New Delta Unifence #34-897

\$ 1,296.00  
795.00  
425.70

\$ 2,516.70

Cash discount

51.70

\$ 2,465.00

Tax Exempt Cert. #042-73-017

**Title to property described above to remain in Seller's Name  
until fully paid for in cash.**